



Rotary Dry Syrup Powder Filling Machine

[DRYFILL-120R Automatic 16 Head Rotary Dry Syrup Powder Filling Machine](#)

The Automatic High Speed *16 Head Rotary Dry Syrup Powder Filling Machine* Model DRYFILL-120R is suitable for Glass, Plastic, PET, HDPE, LDPE Bottles with maximum speed of 120 Bottles per minute depending on Powder Fill Volume, Type of Powder, Bottle Diameter and Bottle Neck Diameter.

Machine in Stainless Steel Finish with heavy duty frame structure with S.S, Clading. All parts coming in contact with Powders are made from SS316 Materials as well as HDPE Funnels.

The Machine works on proven time tested Vacuum and Air Systems to Fill powder in Bottle achieving higher speed and higher accuracy. Machine with unique Bottle Lifting and Neck Holding system avoid spillage of powder on bottle shoulder, neck and body keeps bottle clean and also avoid wastage of powder.

Machine with complete synchronization of Bottle Infeed StarWheel, Powder Wheel movement and outfeed Starwheel for smoother operation. Machine with Rotary Bottle Moving system ensures very high speed powder filing through independent moving funnel along with bottles for greater speed and performance without compromising speed and fill accuracy. Machines with unique vibratory system inside the funnel helps filling of semi free flow type powder at higher speed.

SPECIAL / OPTIONAL* FEATURES :

- No Bottle - No Fill System
- Rotary Bottle Movement System with Rotary Funnel System
- Funnel with Unique Vibratory system for filling semi free flow powder at higher speed
- All contact parts with easy removal system for Cleaning / AutoClaving / Sterilization
- Machine construction in SS304 material
- Filling Accuracy of +/- 1 to 2% depending on powder at controlled humidity below 30% Rh
- Automatic Infeed and Exit of Bottles through Star Wheel System
- No Bottle at infeed conveyor - Automatic Machine on/off system
- Low Air - Machine Stop System
- Low Vacuum - Machine Stop System
- Toughened Glass Safety Cabinet*
- Blower for dust extraction

TECHNICAL SPECIFICATIONS

Bottle Diameter : Upto 85mm*, Square or Rectangular bottles can be used

Bottle Height : 100mm* Maximum

Fill Range : 5gms. To 70gms. In Single Dose with the help of change parts for different fill volume

Fill Accuracy : +/- 1 to 2% Depending upon the Powder, under the controlled level of Humidity

Humidity : Below 30% Rh required on machine to be arrange by customer

Electrical : 415VAC 3Phase and 220 VAC Single Phase Power Supply (50 Hz) with A.C. Drive

Power : 2.0 H.P. For Machine and 3.0 H.P. For Vacuum Pump

Compressed Air :Filtered, Oil Free 2kg/cm² provided by customer only

Vacuum : 28" Hg. @ 300 LPM, provided by Customers only, 500LPM recommended

Conveyor Height : 815-940 mm

Overall Dimensions : 2000 mm (L) x 1200 mm (W) x 1800 mm

Speed : Max. 120 Bottles per minute depending on Bottle Size, Bottle Neck Diameter, Type of Powder and Fill Volume

* Specification can be changed as per customers requirements

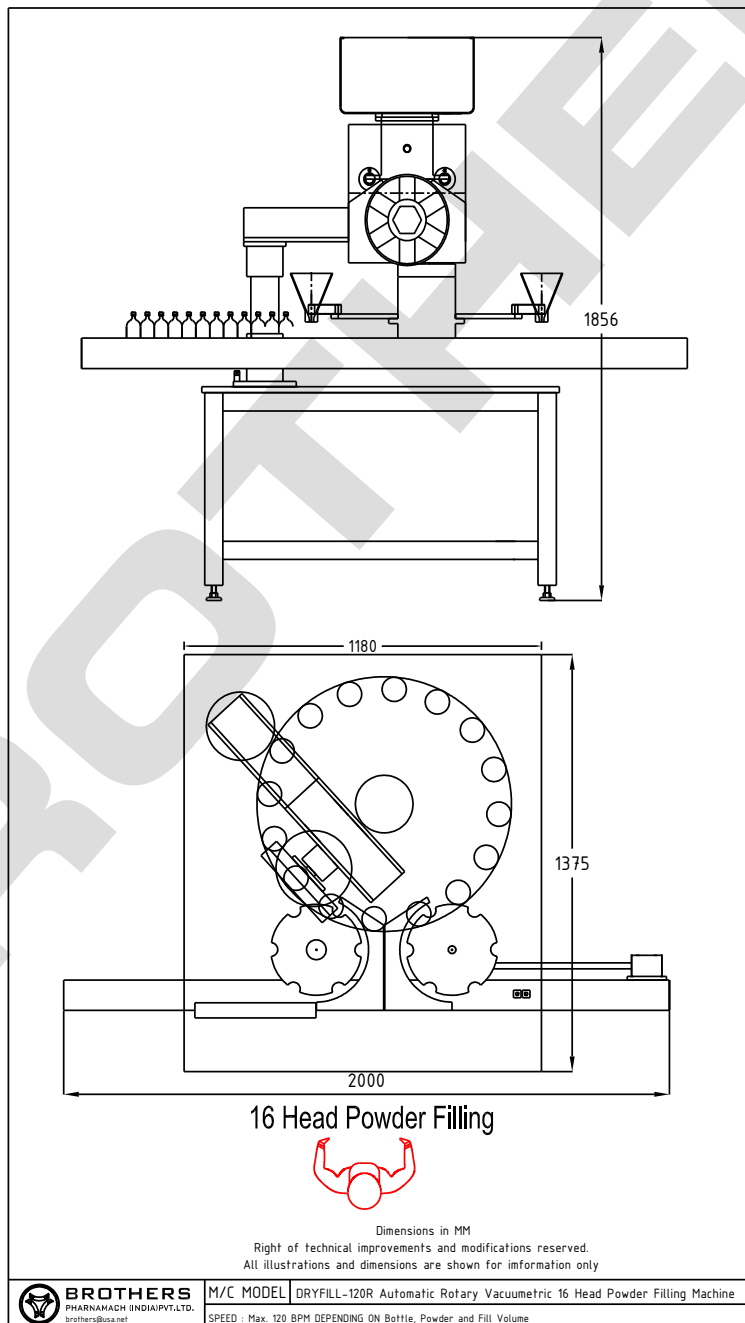

BROTHERS PHARMAMACH (INDIA) PVT. LTD.

Plot No.2, Phase II, GIDC, Vatva, Ahmedabad 382445. INDIA
Phone : +91 79 40213213, 25831346 Fax: +91 79 40213220
+91 9825037971, 9825006052

Email : info@brothers.in mevada@usa.net Website : www.brothers.in